

Heir Traditional Basin Mono - MSTAE1

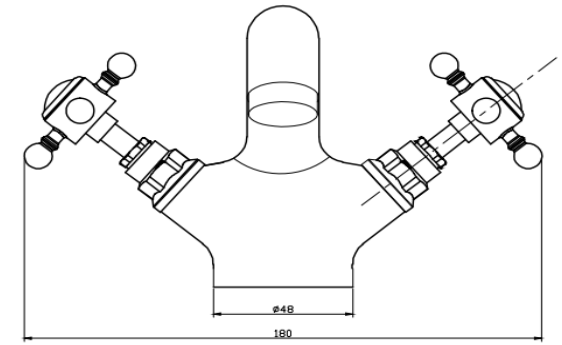

CONSTRUCTION	Brass Body (CuZn40Pb2), EN CW617N (Equivalent to BS CZ122) Zinc-Alloy and Ceramic Handles
FINISHES	Chrome Plated to BS EN 248
PRODUCT TYPE	Traditional
WATER PRESSURE	Min. 0.2 Bar, Max. 6.0 Bar
PLUMBING SYSTEMS	Suitable for All Plumbing Systems, Max. Supply Pressure Differential Requirement No Greater Than 5:1
STANDARDS	Complies with BS5412, BS EN200
NET WEIGHT	1.6 Kg
AERATOR	Spout Aerator
FITTING	Brass G3/4" BSP tails
ADDITIONAL INFORMATION	Supplied with Chrome Stainless Steel 1.5m Hose

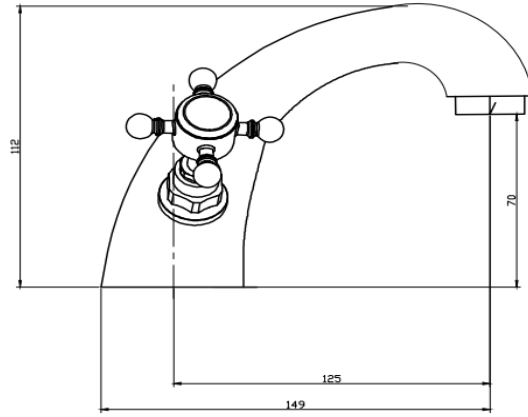

Flow Rates (Litres per minute)

SYSTEM PRESSURE	0.1 Bar	0.2 Bar	0.3 Bar	0.5 Bar	1.0 Bar	1.5 Bar	2.0 Bar	3.0 Bar	4.0 Bar	5.0 Bar
	-	4.9	-	6.9	10.3	-	13.4	-	-	16.2

The information contained on this page was correct at date of issue. Fitting dimensions are provided as a guide only. Some variation may occur due to manufacturing tolerances. We pursue a policy of continuing improvement in design and performance of our products and so reserve the right to change specifications without prior notice.