

Enya Basin Mono - MSTAE1

CONSTRUCTION	Brass Body (HPb59-1), Equivalent to BS CZ122 / EN CW617N / CuZn40Pb2; Zinc-Alloy Handles & Base Plates
FINISHES	Chrome Plated to BS EN 248
PRODUCT TYPE	Contemporary
WATER PRESSURE	Min. 0.2 Bar, Max. 6.0 Bar
PLUMBING SYSTEMS	Suitable for All Plumbing Systems, Hot and Cold Water Pressure Preferably Balanced Max. Supply Pressure Differential Requirement No Greater Than 5:1
STANDARDS	Complies with BS6920, BS EN200
NET WEIGHT	1.45 Kg
CARTRIDGE	35mm Ceramic Disc Cartridge
FITTING	M10 x 350mm G1/2" BSP Female Flexi Tails
AERATOR	M24*1 ABS Spout Aerator
ADDITIONAL INFORMATION	Supplied with G1¼" Sprung Waste

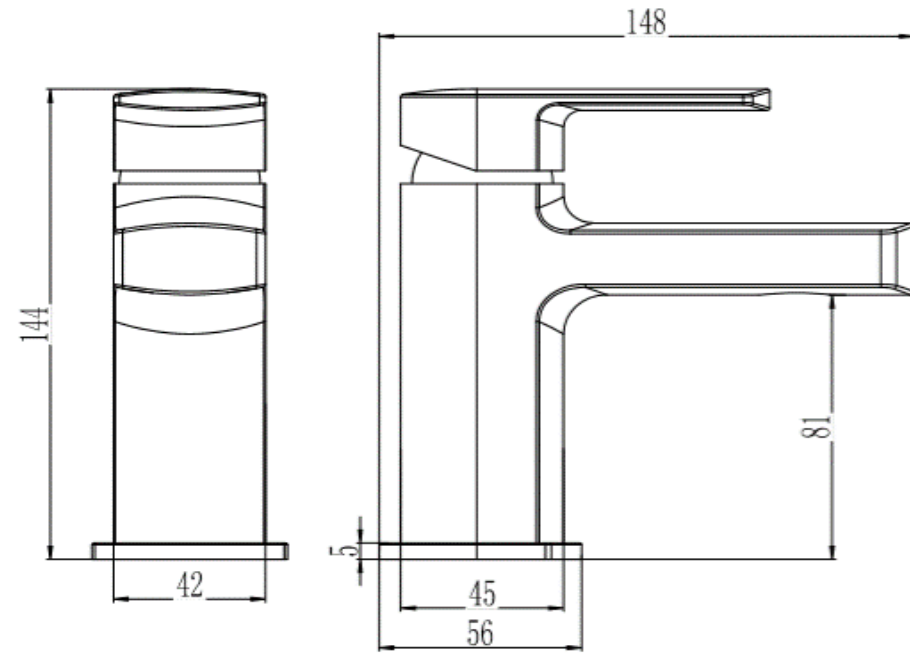

Flow Rates (Litres per minute)

SYSTEM PRESSURE	0.1 Bar	0.2 Bar	0.3 Bar	0.5 Bar	1.0 Bar	1.5 Bar	2.0 Bar	3.0 Bar	4.0 Bar	5.0 Bar
	-	5.1	-	7.8	11.3	13.7	16.7	18.2	-	-

The information contained on this page was correct at date of issue. Fitting dimensions are provided as a guide only. Some variation may occur due to manufacturing tolerances. We pursue a policy of continuing improvement in design and performance of our products and so reserve the right to change specifications without prior notice.