

Atmore 500mm 2 Door Floor Unit - Short Projection

RANGE	Atmore
CODE	MSFAT50FMWH MSFAT50FMGR MSFAT50BA
SIZE (MM)	H 868 x W 490 x D 280 inc. Basin
FINISH	Matt/Gloss
BASIN MATERIAL	Ceramic
TAP HOLE(S)	One
NET WEIGHT	Unit: 18.5 Kg , Basin: 7.9 Kg
ADDITIONAL INFORMATION	<ul style="list-style-type: none"> Compatible with 500mm 1th Ceramic Basin- Short Projection No Overflow, needs Unslotted Waste

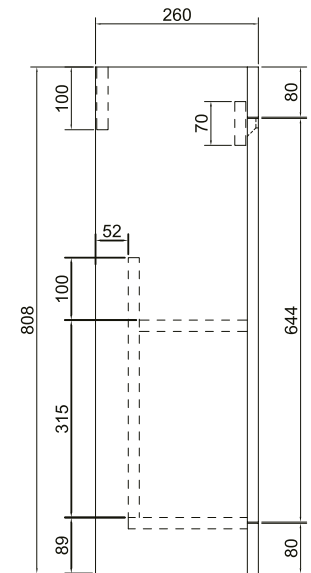

COLOUR OPTIONS:

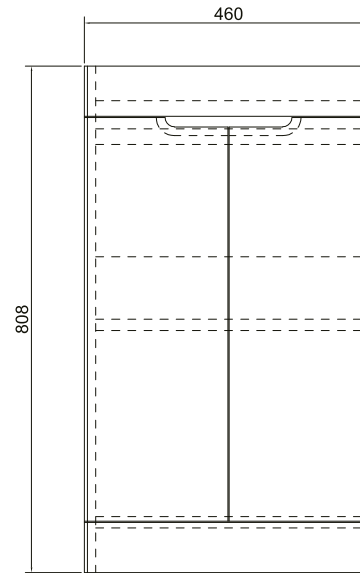

White
Gloss

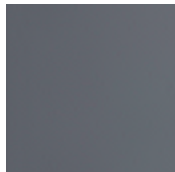

Grey
Matt

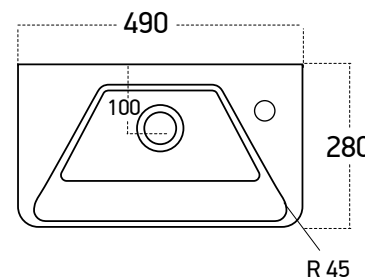
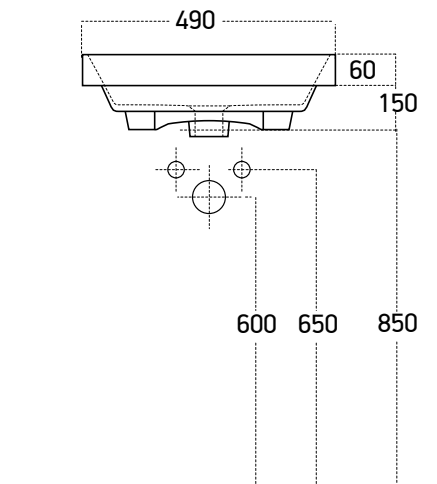
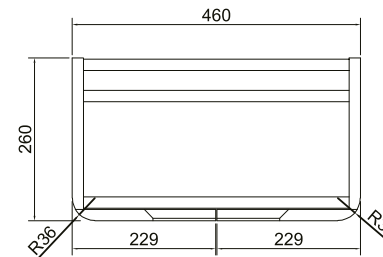

The information contained on this page was correct at date of issue. Fitting dimensions are provided as a guide only. Some variation may occur due to manufacturing tolerances. We pursue a policy of continuing improvement in design and performance of our products and so reserve the right to change specifications without prior notice.